

Automatik Hochdruckschlauchaufroller

R+M 544

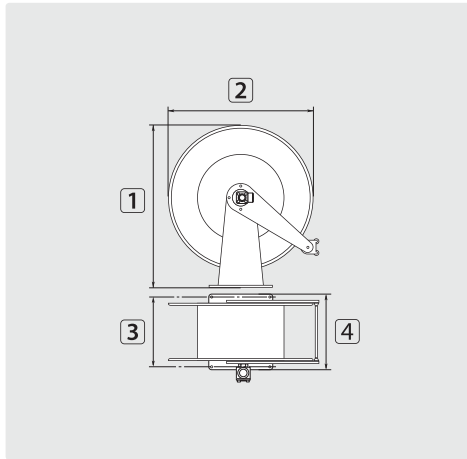
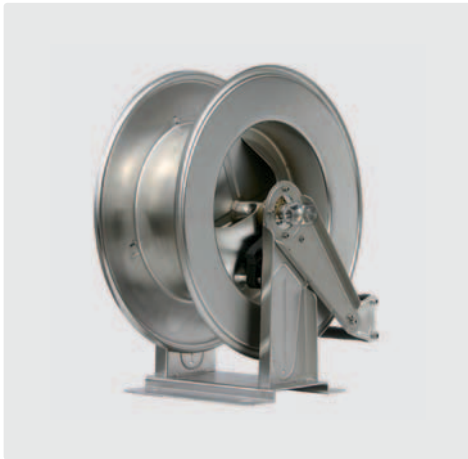

TYP	Außen Ø = Schlauch
03	22,0 mm = 30 m
03	28,0 mm = 22 m
03	34,0 mm = 17 m

R+M Nr.	★	⊕	⊖	DN	P	°C	⊘	1	2	3	4	TYP
763 544 30	■	1/2" IG	1/2" IG	12	300 bar	90 °C	24,0 kg	573 mm	510 mm	218 mm	300 mm	03
763 544 20	■	1" IG	1" IG	19	100 bar	90 °C	24,0 kg	573 mm	510 mm	218 mm	300 mm	03

R+M 564

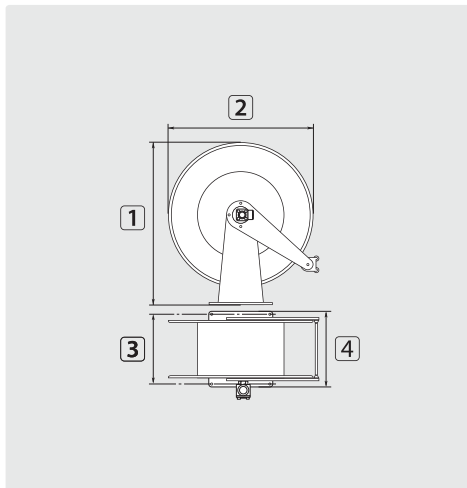
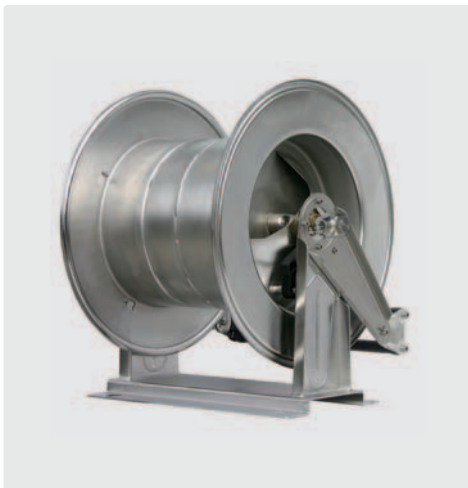

TYP	Außen Ø = Schlauch
04	22,0 mm = 60 m
04	30,0 mm = 40 m
04	35,0 mm = 30 m

R+M Nr.	★	⊕	⊖	DN	P	°C	⊘	1	2	3	4	TYP
763 564 30	▼	1/2" IG	1/2" IG	12	300 bar	90 °C	30,0 kg	578 mm	510 mm	399 mm	488 mm	04

Zubehör Hochdruckschlauchaufroller

Wand- und Schwenkkonsolen



Edelstahl V2A / AISI 304. 80° schwenkbar

R+M Nr.	★
763 430 06	●
763 530 06	▲
763 540 06	■

Befestigungsplatten



Edelstahl. Optional als Montagehilfe

R+M Nr.	★
763 430 02	●
763 530 02	▲
763 540 02	■
763 560 02	▼

Drehgelenke ST-322



Dichtsätze Drehgelenke ST-322

R+M Nr.
200 322 490

⊖ M28 AG. DN 12. Max. 300 bar / 90 °C

R+M Nr.	1	⊕
200 322 523	79,5 mm	1/2" IG
200 322 525	79,5 mm	3/8" IG